

The FramePro® 701XP nailers are designed with the Pro in mind. XtremePro models have improved internal and external features for improved durability and comfort. These compact framers are easy to handle, and easy on the arm. The 30° short, in-line magazine, provides excellent maneuverability and line of sight. Drive a wide range of fasteners from 2" to 3½" to handle virtually any job.



XP
XTREMEPRO™



Applications:

For framing, truss building, sub flooring, sheathing, decking, wood-to-concrete block, siding, fencing, pallets and crate assembly

Features and Benefits:

- Five-year limited warranty
- Upgraded XtremePro internal features include: anodized sleeve for additional strength and durability; urethane sleeve cap protects sleeve from wear; fixed firing valve improves tool life and speed; and positive stop guide body aligns nail and driver for consistent drive
- Comfort and convenience features include: overmold grip and trigger, 360° adjustable exhaust, rafter hanger and construction ruler
- Aggressive sawtooth safety that really digs in for toenailing
- Straight-line 30° magazine for better line of sight and simple two-step loading
- Last nail lock out, prevents dry firing

Tool Specifications:

Item#: 2H0133N Sequential
 Power: 904 in/lbs
 Weight: 8.0 lbs (3.6 kg)
 Height: 3¼" (336.5 mm)
 Length: 14¼" (362 mm)
 Nail Capacity: 56-80, depending on gauge
 Reg. Operating Pressure: 70–120 psig
 Mode of Operation: Available with either Restrictive Trigger or Dual Action activating mechanisms.

Fastener Specifications:

FramePro 701XP nailer drives 2" to 3½" smooth shank nails (Sencote® or plain); 2" to 3" ring-shank nails; 3" screw-shank and clipped "D" head nails. Shank diameters include .113", .120" and .131".

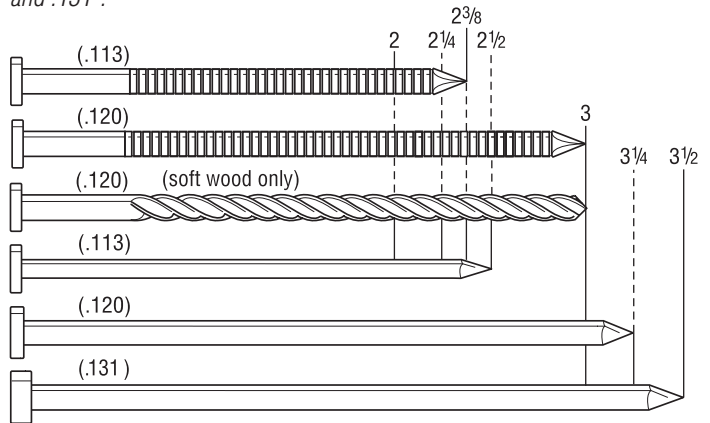

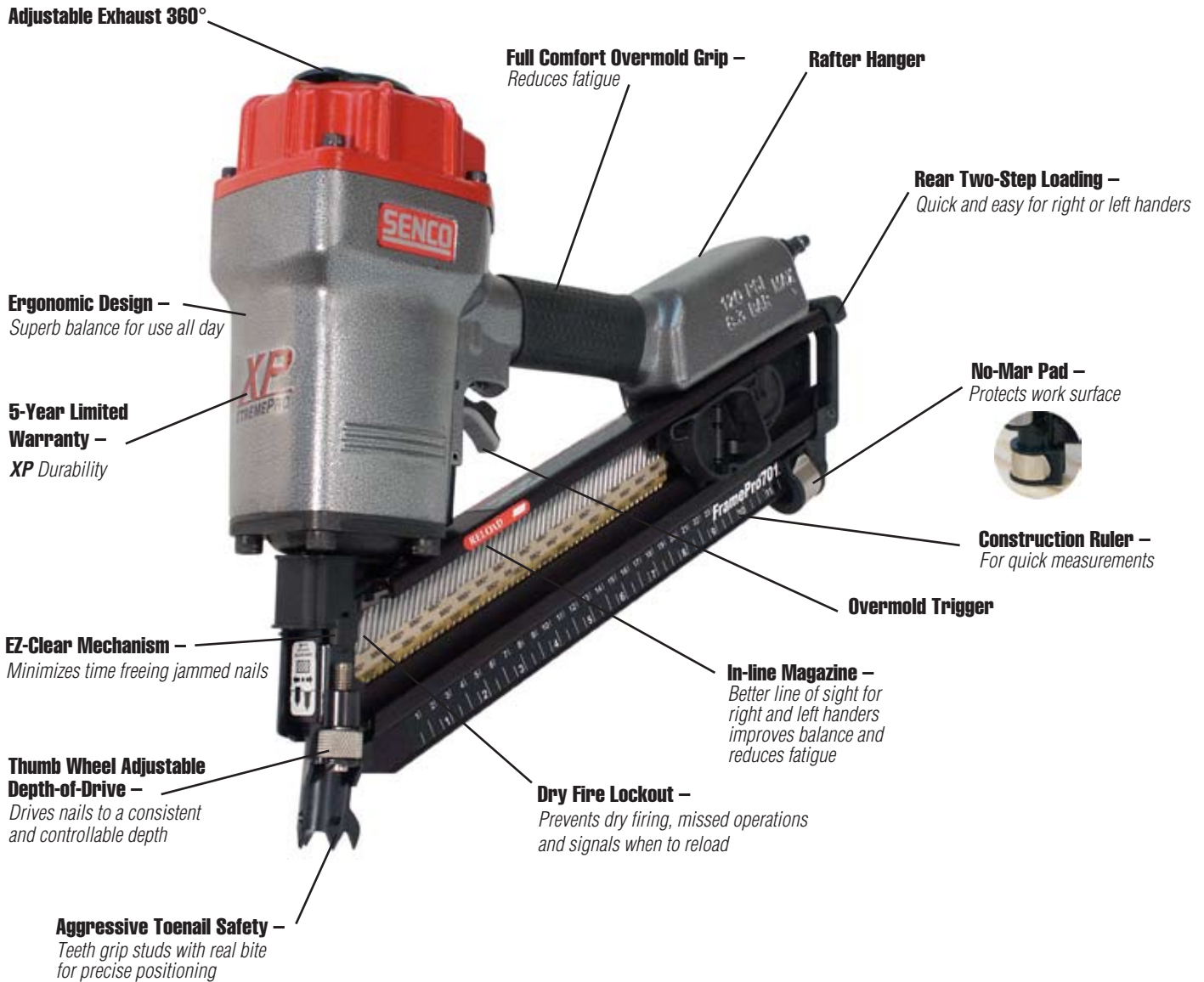

Choose the right trigger system for your specific needs!

Sequential Actuation Trigger (also known as restrictive trigger or trigger fire) operates in the following sequence - depress the safety element at the nose of tool against the work surface then pull the trigger. After each fastener is driven, release the trigger and lift the tool off the work surface before starting the sequence again. This trigger is recommended and acceptable for most applications.

Contact Actuation Trigger (also known as dual action, bounce or bottom fire) operates in the following sequence- pull the trigger first and keep the trigger pulled while moving the tool along the work surface with a bouncing motion, depressing the safety element at the nose of the tool against the work surface where the fastener is to be driven. This trigger is recommended for use by trained professionals only in high production or volume applications.

Always read the Operators Manual and Safety Instructions with all tools to ensure proper use and safety precautions. For additional information on trigger systems and how SENCO will save you time, reduce costs, and increase quality, call our toll-free Action Line: 800-543-4596 to find your nearest Authorized Senco Dealer, Distributor or visit our web site at: www.senco.com



161 DOAN STREET BOX 825
WILMINGTON, OHIO 45177
(937) 382-3501
www.deequipment.com